

POLYS P-1

**Thermostatic Welder
for Socket Fusion Welding**

Directions for Use

Dear Customer,

The equipment you have just bought was manufactured by DYTRON EUROPE s.r.o., a world-wide recognised manufacturer of plastic welding equipment. We believe you would be satisfied with its quality and reliability.

Before putting the equipment into operation for the first time, please read these Operating Instructions carefully. They provide you with important information on safe and correct operation and maintenance.

Principles of the Welder Use

- ▶ Use socket welder for welding of plastic pipes in the environment free from aggressive gases, combustibles and explosives.
- ▶ Protect your welder from shocks that could result in controller damage, or damage to the welder as a whole.
- ▶ Put aside your welder into a fixed clamp or lay it with its stand upon a flat incombustible pad.
- ▶ If the welder is put aside with its heating element still hot, it should not touch other materials.
- ▶ The heating element must not touch the power cord.
- ▶ Do not insert any objects into the openings of perforated cover; the thermal-insulating basket may not be covered.
- ▶ Adapters may be replaced with the welder switched off only.
- ▶ Do not touch the heating element or the welding adapters with bare hands.
- ▶ Wear protective gloves when replacing welding adapters.
- ▶ According to EN 60 335-1, poly-fusion welders are classified as hand-held tools of Class I; for safety reasons, for work in normal environment, it is therefore necessary to connect them only to a socket that is properly grounded (this also applies to connecting with extension cords, which must be three-cored and connected according to standards in force). The socket must be protected by a current protector.
- ▶ Store hot adapters in the welding set case or on an incombustible pad after use.
- ▶ When you have finished your work, switch off the welder by pulling the power cord from main socket.
- ▶ Do not disassemble the welder.
- ▶ In the event that the power supply cord of this

appliance is damaged, it should be replaced by the manufacturer or an authorised service engineer or other adequately qualified person in order to avoid the occurrence of an accident.

- ▶ For safety reasons, use power sockets with properly grounded pins only. The socket should be protected with a ground fault interrupter.
- ▶ An isolation transformer must be used for protection when working in outdoor environment.
- ▶ Avoid using damaged, unprofessionally repaired extension cables or cables of unknown origin.
- ▶ For work safety purposes, we recommend to check the correct connection of the power socket before connecting the power cord to the welding equipment, and in case of using a cable extension to check the extension as well.
- ▶ If any mechanical damage to the welder or the power feeding cable occurs, disconnect the power cord from the socket and do not use the welder anymore and hand it over to the authorised service for repair.

Storage conditions:

Temperature: -10 to +60°C

relative humidity: <75 %, no condensation

Operating conditions:

Temperature: -5 to +40°C

relative humidity: <90 %, no condensation

Socket welder may not:

- ▶ get into contact with water
- ▶ be used in damp environment
- ▶ be used in works not designed to
- ▶ be suspended on the power cord
- ▶ be left switched on unattended

Socket welder POLYS P-1a 650 W ROD

This welder is ideal for welding in less accessible places. It is designed to combine the cylindrical heating element with the patented solution of welding adapters.

In case of welding with one or two welding adapters it is necessary to fix the adapters in the upper part of the heating rod (in case of one adapter only in the upper third of the rod).

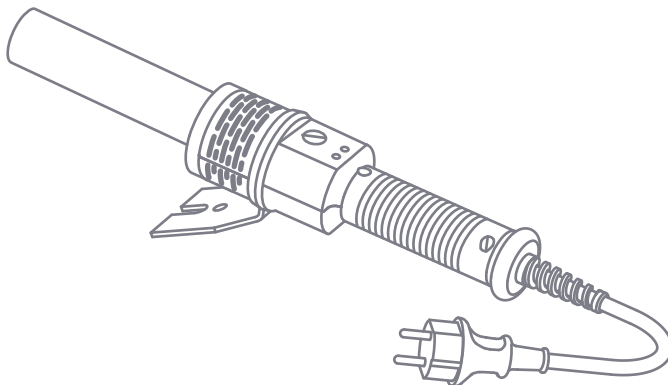

POLYS P-1a 650 W

TECHNICAL DATA

Type of welding	Socket welding
Welding diameter	16 – 63 mm
Type of adapters	Jaw adapters
Power demand	650 W
Voltage	230 V, 50 Hz
Temperature control	Thermostatic regulator
Thermal stability	15° C

TYPES OF SETS AVAILABLE

P-1a 650 W		SOLO	MINI	MINI PLUS
		Weight 1,6 kg	Weight 5,1 kg	Weight 5,6 kg
Socket Welder		✓	✓	✓
Jaw adapters (Black coating)	Ø 20 mm		✓	✓
	Ø 25 mm		✓	✓
	Ø 32 mm		✓	✓
	Ø 40 mm			✓
Cardboard box	✓			
Sheet metal case MINI		✓	✓	
Workbench clamp		✓	✓	✓
4 mm Allen key	✓	✓	✓	✓
DYNO Shears up to 42 mm				✓

Socket welder POLYS P-1a 850 W knife

Up to 2 adapters simultaneously can be clamped on the knife-shaped heating element. The welder features very good temperature transfer from the heating element to the adapter and the increased thermal capacity. For this reason, it is not necessary to make any temperature correction when using larger adapters. Temperature adjustment, as well as welder operation indication, is identical to POLYS P-1a welder with heating rod.

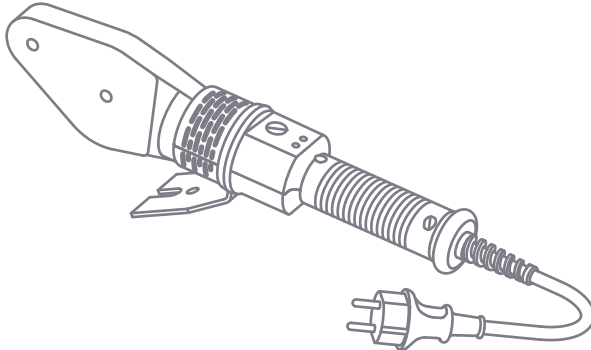

POLYS P-1a 850 W

TECHNICAL DATA

Type of welding	Socket welding
Welding diameter	16 – 75 mm
Type of adapters	Pair adapters
Power demand	850 W
Voltage	230 V, 50 Hz
Temperature control	Thermostatic regulator
Thermal stability	15° C

TYPES OF SETS AVAILABLE

P-1a 850 W		SOLO	MINI	MINI PLUS
		Weight 2,0 kg	Weight 5,3 kg	Weight 5,9 kg
Socket Welder		✓	✓	✓
Pair adapters (Black coating provides)	Ø 20 mm		✓	✓
	Ø 25 mm		✓	✓
	Ø 32 mm		✓	✓
	Ø 40 mm			✓
Cardboard box		✓		
Sheet metal case HOBBY				
Sheet metal case MINI			✓	✓
Workbench stand		✓		✓
Workbench clamp			✓	✓
6 mm Allen key		✓	✓	✓
DYNO Shears up to 42				✓

Socket welder POLYS P-1b 500 W angle rod

This welder is ideal for welding in less accessible places. The adapters are replaceable easily even when hot. Working temperatures are adjustable within the range of 180 - 280°C by means of a rotary control knob located on heating head sheet metal cover.

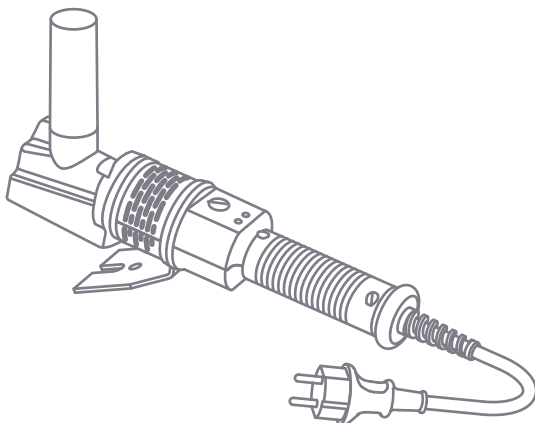

POLYS P-1b 500 W

TECHNICAL DATA

Type of welding	Socket welding
Welding diameter	16 – 40 mm
Type of adapters	Jaw adapters
Power demand	500 W
Voltage	230 V, 50 Hz
Temperature control	Thermostatic regulator
Thermal stability	15° C

TYPES OF SETS AVAILABLE

P-1b 500 W		SOLO	MINI
		Weight 1,6 kg	Weight 6,7 kg
Socket Welder		✓	✓
Jaw adapters (Black coating provides)	Ø 16 mm		
	Ø 20 mm		✓
	Ø 25 mm		✓
	Ø 32 mm		✓
	Ø 40 mm		✓
Cardboard box		✓	
Sheet metal case HOBBY			
Sheet metal case MINI			✓
Workbench clamp			✓
4 mm Allen key		✓	✓
DYNO Shears up to 42			✓

	1 Temperature adjustment control comb
	2 Red LED - indicates power supply is switched on
	<p>3 Green LED – temperature indication</p> <p>Permanently lit: the temperature of the welder is lower than the set temperature. Do not use the welder before the green LED starts flashing.</p> <p>Flashing: the temperature of the welder is identical with the set temperature; the welder is ready for use.</p> <p>Off: the temperature of the heating element is too high. Wait till the moment the green LED starts flashing.</p>
<p><i>POLYS P-1b 500 W does not have the adjustment of temperature on the front panel, but it is on the regulation screw on the rear part of the welder. All the other adjustment is the same as POLYS P-1a.</i></p>	

Temperature adjustment

Before you start welding it is necessary to check the temperature of the working surfaces of adapters by means of a suitable thermometer! (e.g. DT metr).

Welding Procedure

This working procedure covers only the description of socket welding principle. It does not substitute applicable regulations and professional training of workers.

Socket welding process consists in melting the outer surfaces of plastic pipe ends and the inner surfaces of pipe fittings. Both parts are fitted into each other after having been heated up, resulting in a perfect permanent joint.

Fusion adapters of required diameters should be clamped to the heating element before the welder is connected to power supply. Welder can be laid aside or be fixed in a clamp.

Welder is connected to mains with required temperature set. While the welder is being heated up, time can be spent in preparing pipes and fittings for welding, degreasing them and in cleaning oxidised surfaces to be welded.

After the required temperature is reached, wait for an additional period of 10 minutes to allow heat to distribute evenly, particularly when using adapters of larger diameters.

After that, the fitting is put on the fusion adapter rod and the pipe end inserted into the adapter hollow. When both ends are heated up, they are removed from the adapter and pressed together.

Weld only pipes made out of the same material and from the same manufacturer. Avoid rotating pipes and fittings when joining them together.

- ▶ Allow the joint to cool down. Technological time limits and temperatures are specified by pipe manufacturers.
- ▶ Switch off the welder by pulling its power cord from mains.
- ▶ Fusion adapters may be replaced with the welder switched off only.
- ▶ Wear protective gloves when replacing fusion adapters.
- ▶ Store hot adapters in the welding set case or on an incombustible pad after use.

When you have finished your work, switch off the welder by pulling the power cord from mains socket. Do not disassemble the welder.

For welding of the pipes with the diameter exceeding 50mm, it is necessary to use a suitable fixing device (e.g. MP 75 or MP 110 manufactured by DYTRON EUROPE s.r.o.).

Maintenance

Fusion surfaces of adapters should be kept clean. Wooden spatula or a dry rag of non-synthetic material can be used for cleaning. It is not permitted to clean the welding adapter with metal objects, as this would damage the top anti-adhesive layer.

Keep the welder clean, particularly the contact areas for the adapters. The welder does not require any special maintenance.

All repairs of the welder can be performed by service stations authorised by DYTRON EUROPE s.r.o.

PERFORMING OF REVISIONS

The initial product revision is done by the manufacturer. The user is obliged to carry out revisions (hand welders are hand-held tools of the Class I) according to the requirements of legislation of the country of the user. If there are no legislative rules of this kind, the manufacturer recommends to carry out revisions in the below mentioned periods.

Recommended frequency of revisions

A	Welder is operated only occasionally (up to 100 operating hours / year)	6 months
B	Welder is operated often, for short periods (100 to 250 operating hours / year)	3 months
C	Welder is operated often, for long periods (over 250 operating hours / year)	2 months

The revisions can be made by a service organisation authorised by DYTRON EUROPE s.r.o. or a service organisation with a similar authorisation in compliance with the rules of law of the country of the user.

At least once a year, it is necessary to carry out verification of the welder temperature control.

ATTENTION! If an extension cable is used for connecting the welder to power socket, it is necessary for safety reasons to subject this extension cable to the verification according to EN 66 335-1 together with the welder.

Optional Accessories

Functional dimensions of the welding adapters comply with the requirements of the respective European standards concerning dimensions of the plastic pipes and fittings.

The adapters are coated with a special high-quality blue double-layer anti-adhesive DT coating or with a black one-layer anti-adhesive PTFE coating.

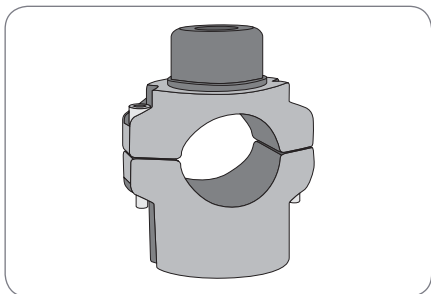

Jaw Adapter

- ▶ For welders with a rod heating element
- ▶ For welding at difficult accessible places
- ▶ Type A as standard, but available also in Type B (for welding of pipes requiring calibration)
- ▶ Increased thermal effectiveness
- ▶ Fixing by using a 4 mm Allen key

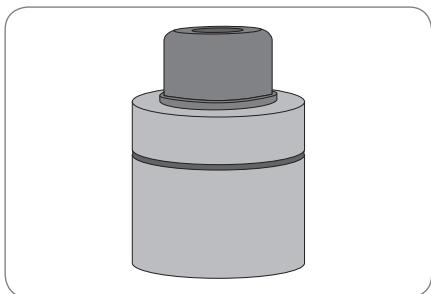

Pair Adapter

- ▶ For welders with a knife heating element
- ▶ Type A as standard, but available also in Type B (for welding of pipes requiring calibration)
- ▶ Available in 16 – 125 mm
- ▶ High thermal capacity
- ▶ Fixing by using a 6 mm Allen key

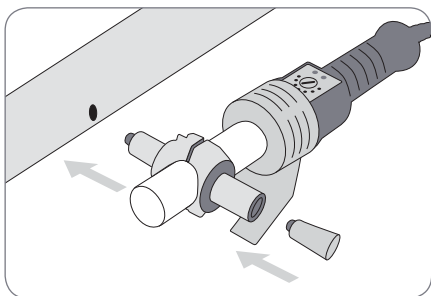

Repair Adapter

- ▶ For welders with a rod heating element For repairs of plastic piping
- ▶ Available standalone or with a repair rod
- ▶ Fixing by using a 4 mm Allen key

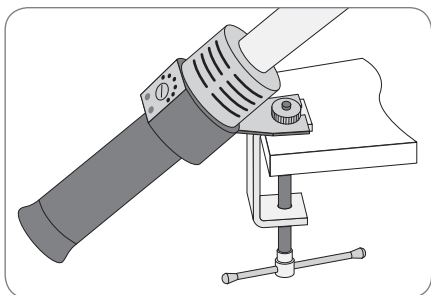

Clamp

- ▶ Designed for all types of welders
- ▶ For fixing the welder onto a workbench and other worktops

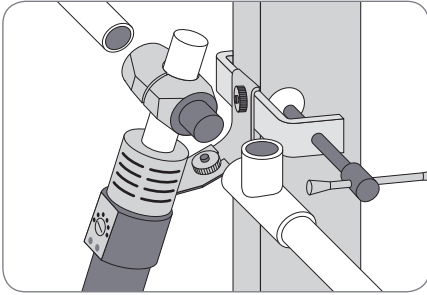

Universal clamp

- ▶ Suitable for attaching the welder to almost any object
- ▶ Designed for all types of welders

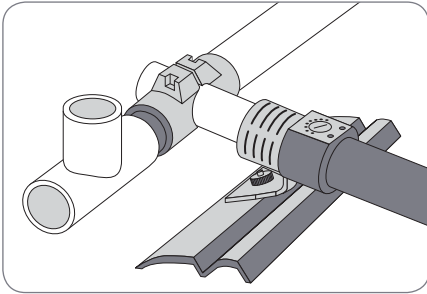

Foot stand

- ▶ For holding the welder by a foot during work
- ▶ Designed for all types of welders

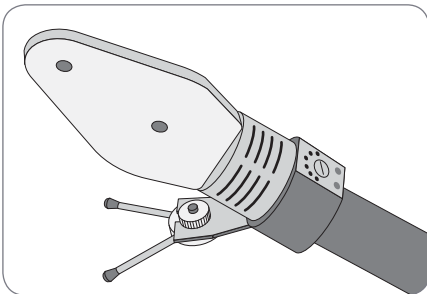

Workbench stand

- ▶ For placing the welder on a workbench
- ▶ For welders with 850 and 1200 W output

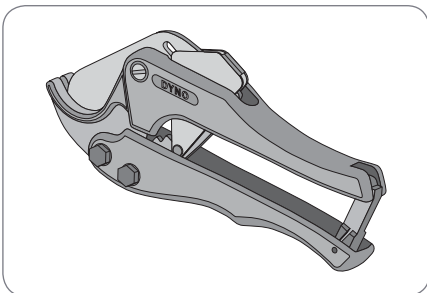

DYNO shears

- ▶ are used to cut plastic pipes up to 40 mm in diameter

Authorised Service Shop

for the Czech Republic

DYTRON EUROPE s.r.o.
Toužimská 943/24a
197 00 PRAHA 9 - Kbely

Tel.: +420 266 190 031, 019